



XM-DI-16 Digital Input Expansion Module

Data sheet applicable for:

- XM-DI-16 : 16 channel Digital Input Expansion Module

Introduction

XM-DI-16 is a 16 channel Digital Input Expansion Module that adds extra digital inputs (DIs) to the XM14-DT or XM17-ADT Programmable Logic Controllers (PLCs).

Features of XM-DI-16

- Easy expansion by using a plug-in bus connection between the PLC and XM-DI-16 module.
- Easy fitment next to the PLC on the 35 mm DIN rail.
- Bus connection routed through an Expansion Connector that also offers protection for cable.
- 16 optically isolated digital inputs that can accept sink or source logic in 2 groups of 8 inputs.
- No external power supply required for the XM-DI-16 which is energized from the bus itself.
- Convenient stacking of multiple expansion modules with connectors available on both sides of the XM-DI-16 unit.

Front view

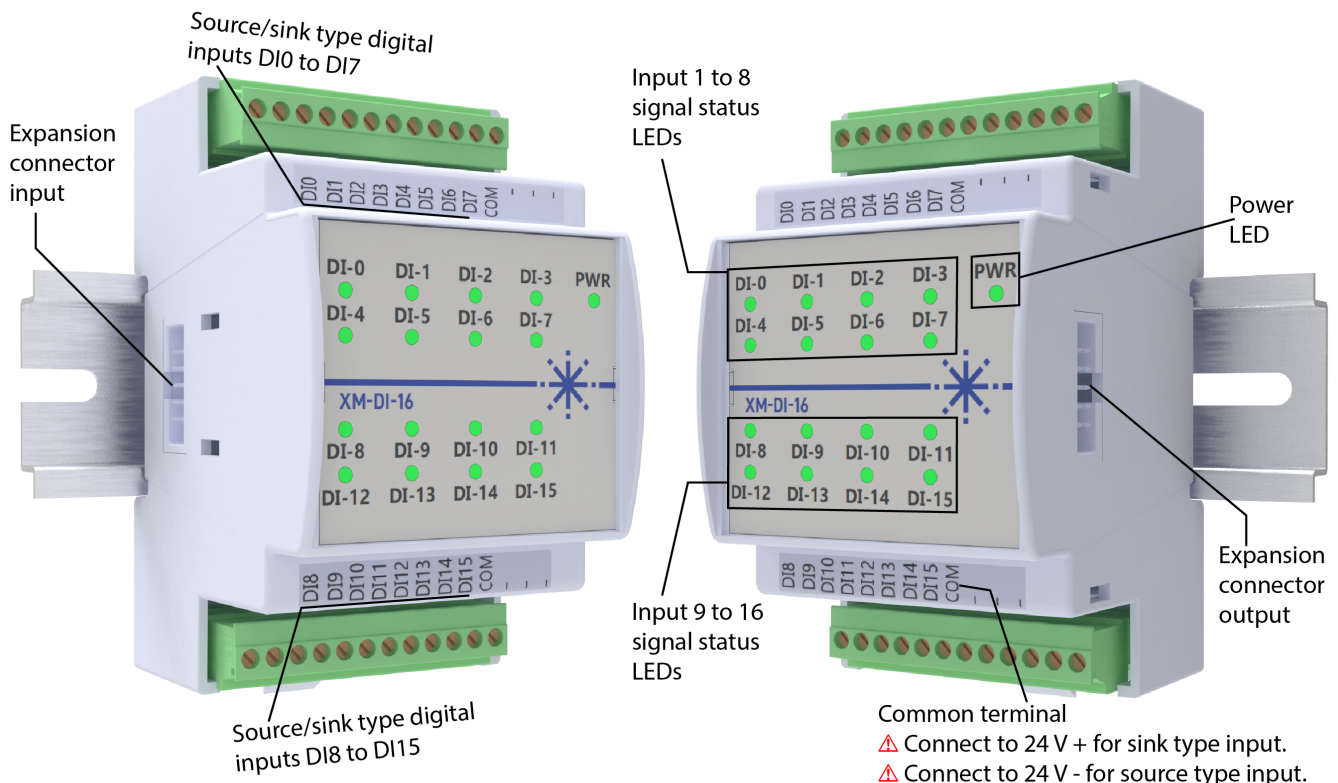

Figure 1. XM-DI-16 Digital Output Expansion Module

Local expansion with XM-DI-16 unit

The following figure shows two Expansion Modules (such as the XM-DI-16) attached to the XM14-DT PLC. Each Expansion Module connector contains a Flat Ribbon Cable (FRC) that connects the PLC with the expansion modules.

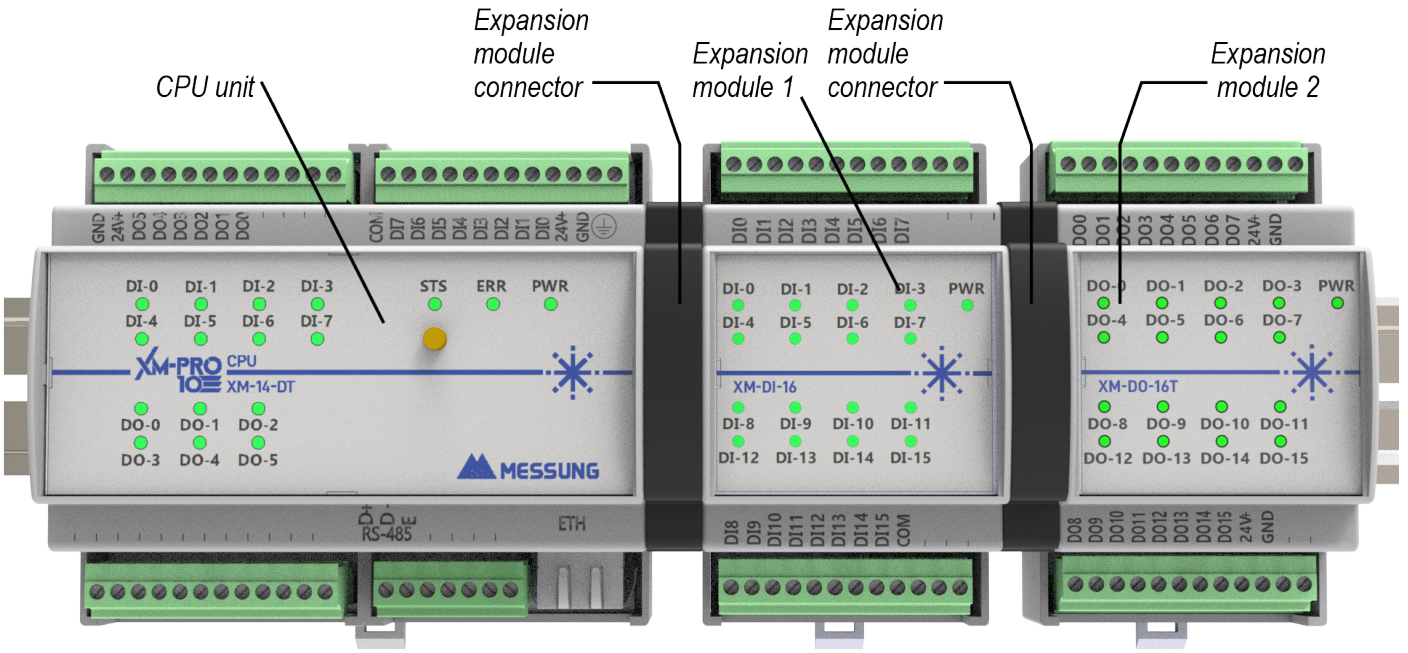

Figure 2. PLC CPU unit 2 expansion modules

Connecting the Expansion Module

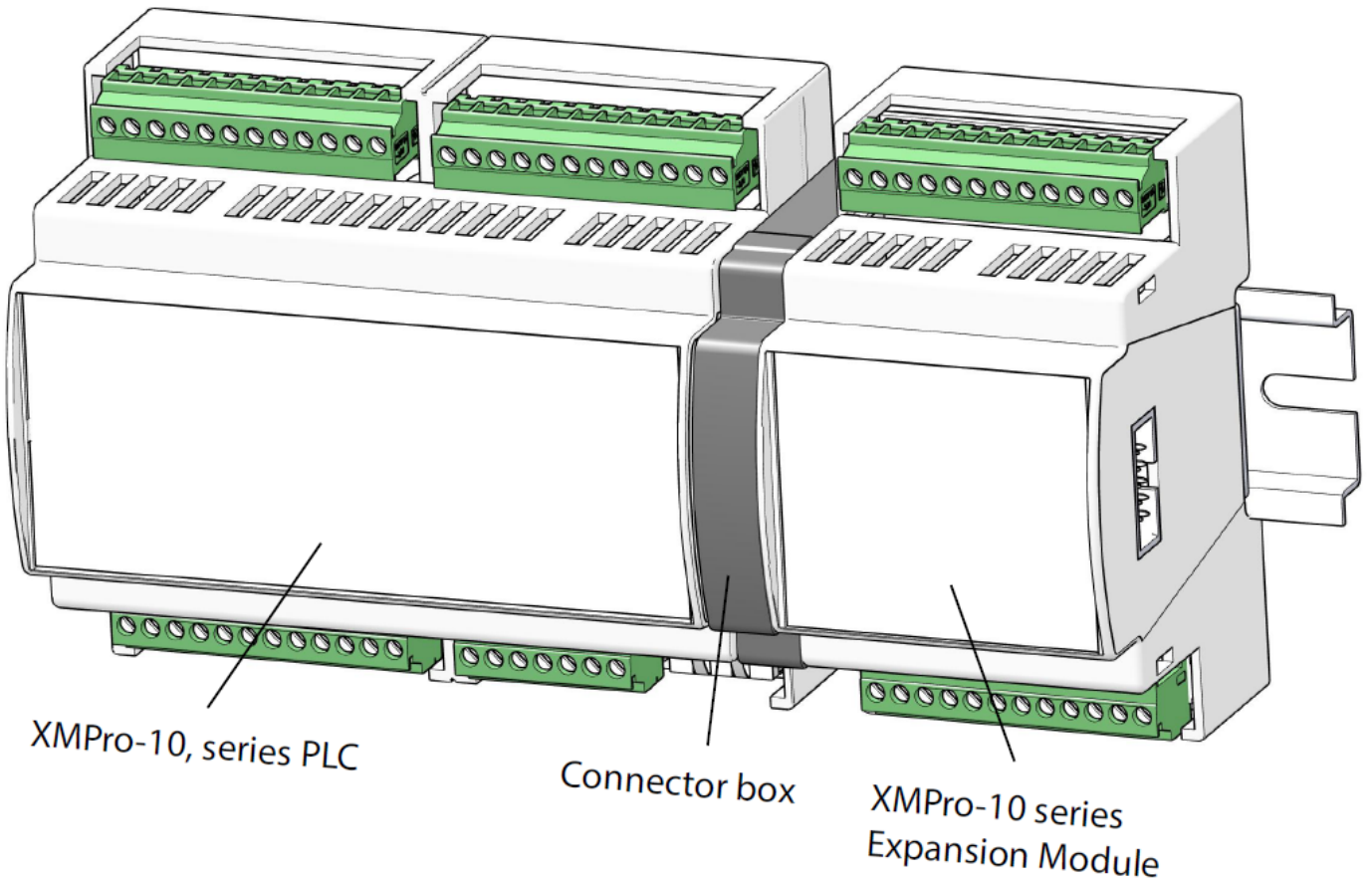

Figure 3. XMPro-10 series PLC and Expansion Module on a 35 mm DIN rail

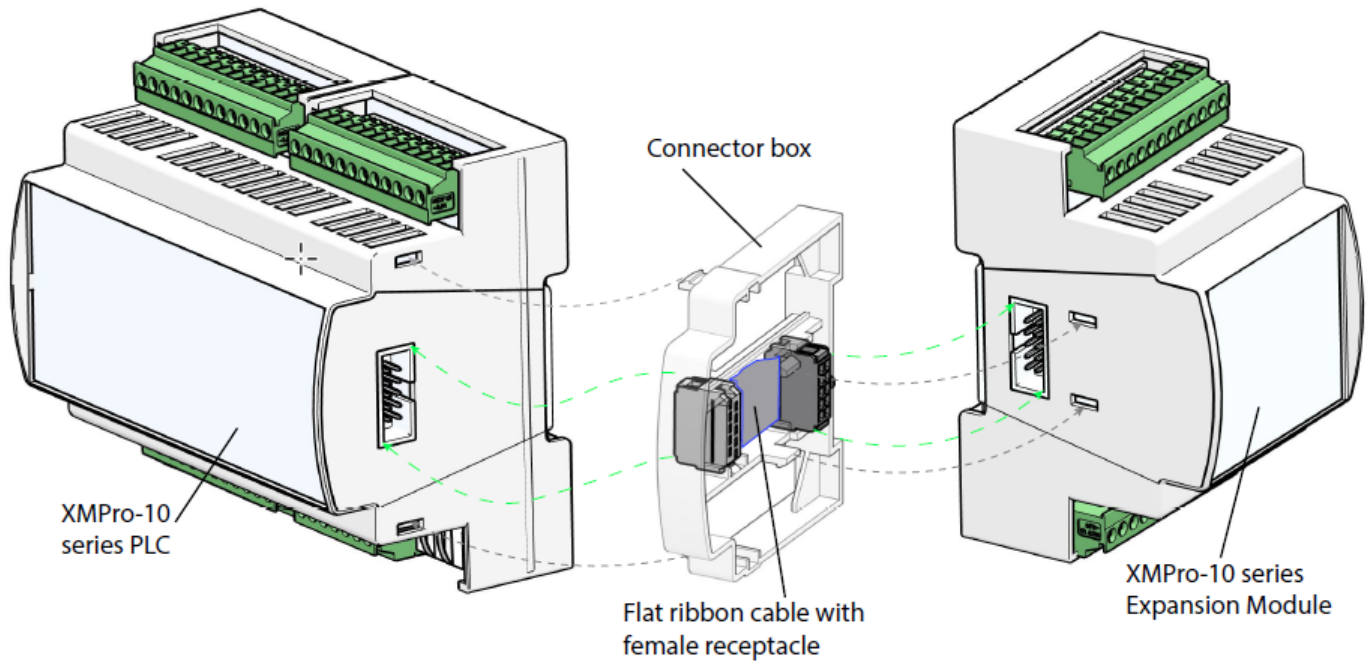

Figure 4. Connecting the XMPro-10 series PLC and Expansion Module

Specifications

XM-DI-16		
Input type	Source or Sink type	
Number of outputs	16	
Input voltage	Voltage (typical)	24V DC
	Voltage range	18 to 30V DC logic
	Connector type	Pluggable Terminal Connector
	0 Signal (low)	0 to 5V DC
	1 Signal (high)	18 to 30V DC
Maximum input power	720mW	
Maximum input current	6mA at 24V DC	
Response time	0.1 milliseconds	
IP level	IP20	
Operating temperature	0°C to 55°C	
Storage temperature	-5°C to +55°C	
Indication lamps	PWR LED (green) and Input State LEDs (green)	
Operating & storage relative humidity	5 to 95% RH (no condensation)	
Certifications	CE ^a , RoHS	
Dimensions	54 mm (width) x 90 mm (height) x 62mm (depth)	
Weight	125 grams	

XM-DI-16	
Maximum wire size	0.5 mm ² with lugs
	1.5 mm ² without lugs
	^a In process

Wiring diagram

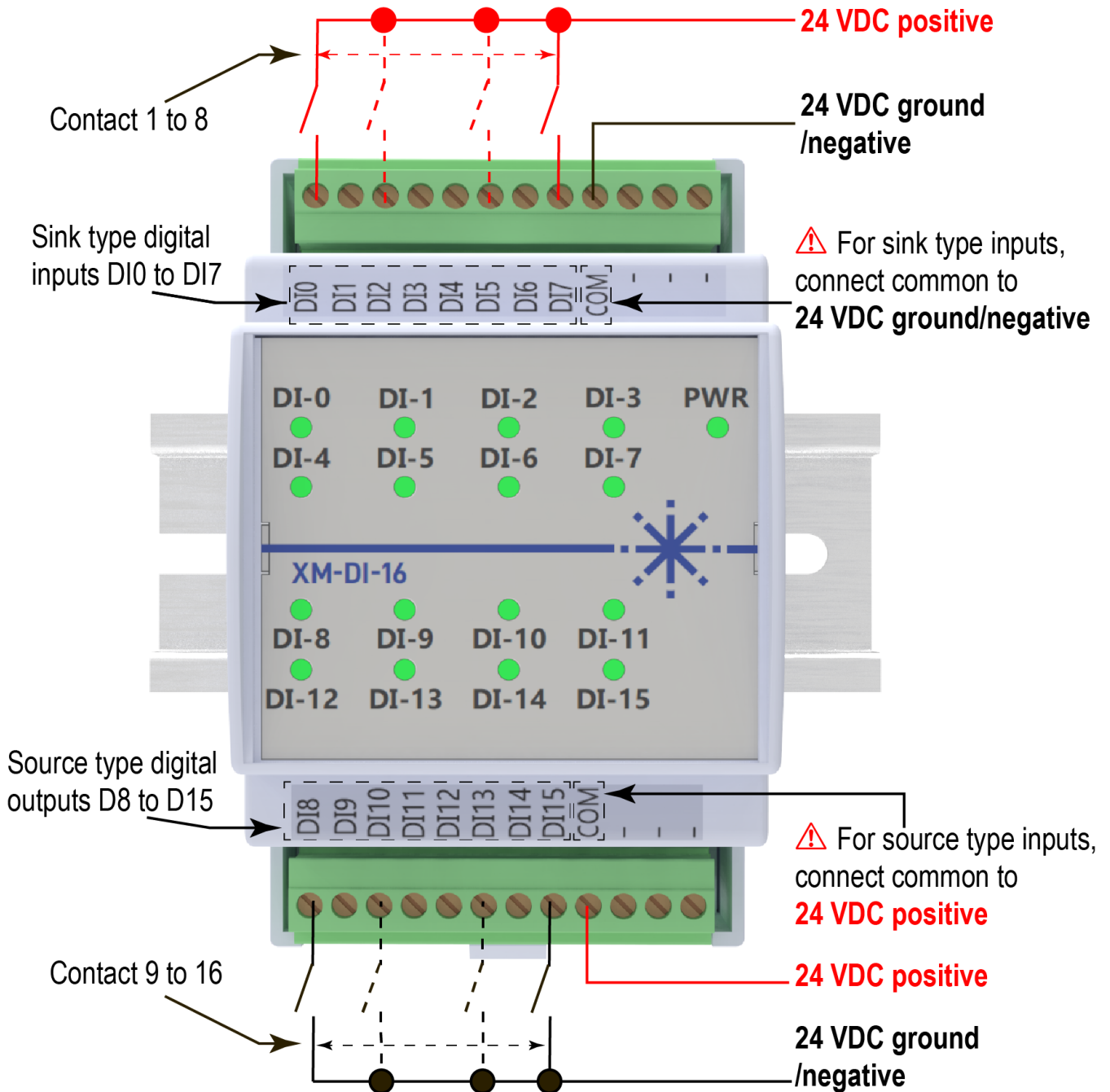

Figure 5. Typical wiring diagram of XM-DI-16 Digital Expansion Module

Fitting and removal

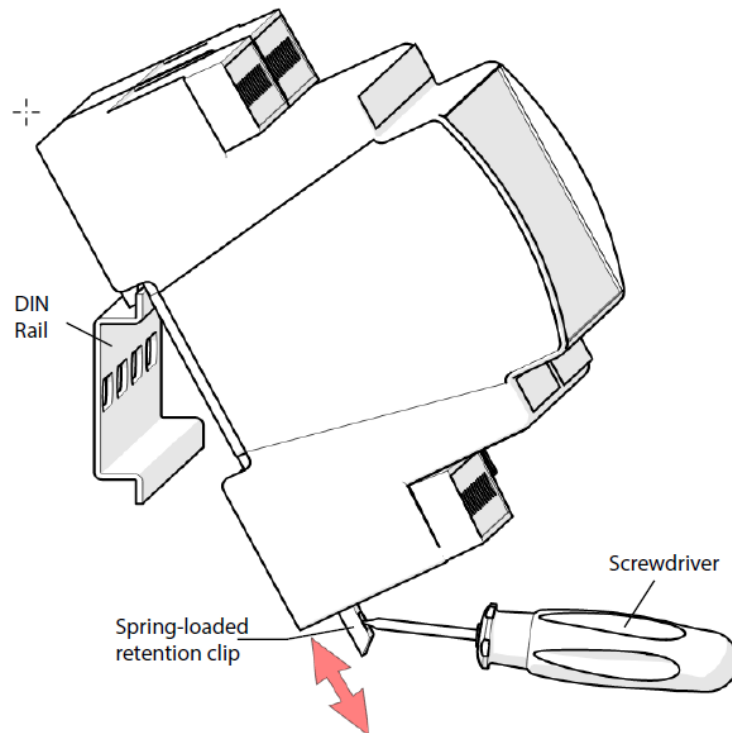

Figure 6. Engage the DIN rail and pull the retention clip

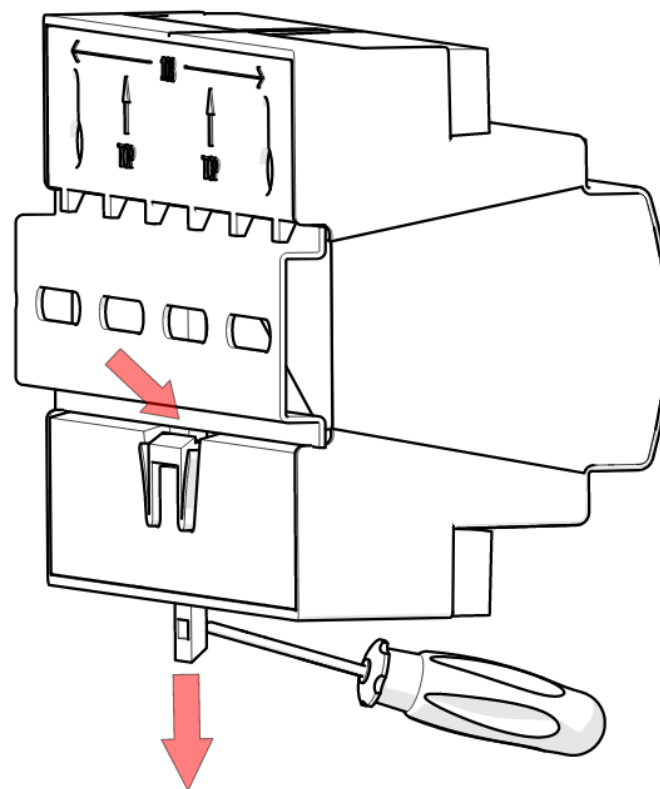

Figure 7. Pull down the spring-loaded retention clip using a flat-blade screwdriver

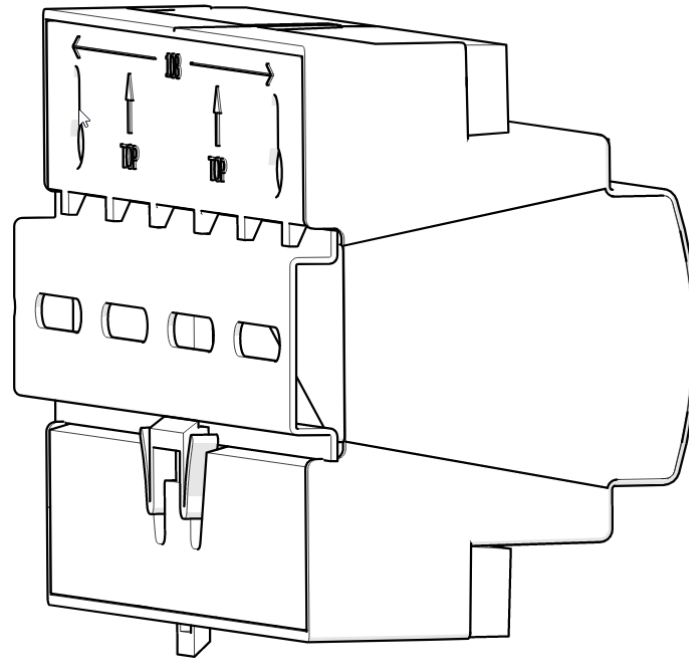

Figure 8. Lock the XM-DI-16 unit on the DIN rail

⚠ XM-DI-16 unit series units fit on a 35 mm DIN rail channel.

1. Engage the slot at rear of unit to the upper edge of DIN rail. Refer Figure 6.
2. Pull down the spring-loaded retention clip using a flat-blade screwdriver.
3. Push the unit onto the DIN rail. Refer Figure 7.
4. Release the retention clip to lock the unit on the DIN rail. Refer Figure 8.
5. Reverse the procedure for removing the XM-DI-16 unit from the DIN rail.

Safety instructions

- ⚠** Do install the unit only by qualified professionals, following all applicable laws and regulations.
- ⚠** Do not connect mains supply or any other external voltage to any terminal of the XmPro10 series unit.
- ⚠** Do ensure that the panel or box with the device is locked to prevent unauthorized access.
- ⚠** Do protect all electrical loads against overloads and short-circuits.
- ⚠** Do ensure adequate ventilation and protection from dripping water.