

4 CH Analog Input Module-Modbus RTU Technical Documentation

# MOD-AI-4

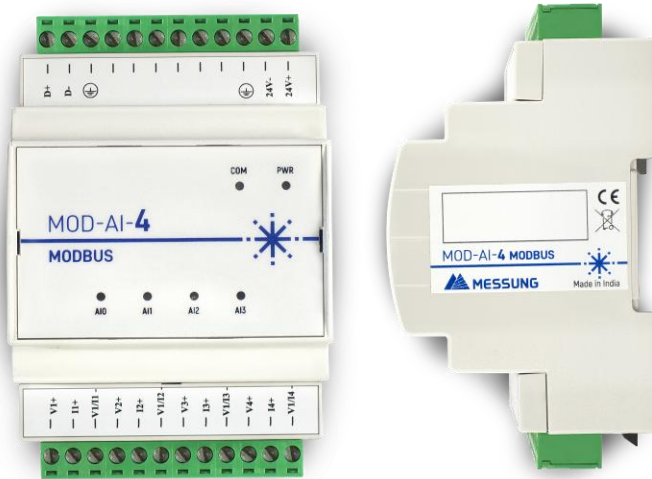

## Features:

- 4 Channel Analog input – (12bit- 0-10v/0-20mA/4-20mA)
- LED indication for each input status, error, communication port and power ON
- DIN rail mount assembly
- DIP switch for Modbus RTU slave configuration
- No configuration software needed
- CE Mark

### General Product Specifications: MOD-AI-4

Application	Industrial Automation	
Supply	Voltage (typical)	24VDC
	Voltage Range	18-30 VDC
	Connection type	Pluggable terminal connector
Communication Interface& Protocol	RS 485& Modbus RTU	
No. of Analog Input Channels	4- Single Ended	
Signal-per Input	1. 0V-10V 2. 4-20mA 3. 0-20mA	
Resolution	12 Bit	
Engineering Scalling	0 - 4095	
Analog Input Field Connections	2-Wire	
Configuration	Individual Input configuration	
Accuracy	± 0.1 % of full-scale rating @ 25°C	
Protection	Input protection against surge voltages	
IP Level	IP20	
Isolation	Isolation between Input and Logic.	
Operating Temperature	0 to 70°C	
Storage Temperature	-25 °C to +75 °C	
Ambient Humidity	5 to 95 % RH (no condensation)	
Dimension	71 (L) X 90.5 (H) X 62 (D) mm [4 DIN Units]	
Calibration	Self	
Filter	Noise suppression filter & digital filter	
Usage	Indoor, to be mounted inside distribution boxes or electrical panels with DIN rail	
Certification	CE	
Operation Indicator	LED (Red) for DC power ON, Flickering Yellow LED to indicate communication	

### Messung Systems Pvt. Ltd.

501 Lunkad Sky Vista, Viman Nagar, Pune 411 014, India.

T: +91 20 6649 2800 | e: [info@messung.com](mailto:info@messung.com) | w: [www.messung.com](http://www.messung.com)

## WIRING DIAGRAM

Modbus Communication Specifications:	
Protocol	Slave Modbus RTU
Baud Rate	9600,19200,57600,115200
Slave Address	1-31
Data Bit	8
Stop Bit	1
Parity	None, Odd, Even
Response Time	<100ms
Termination Resistance	120ohm (Switchable)
Control Registers	Holding Register& Input Register
Distance	Up to 1200m

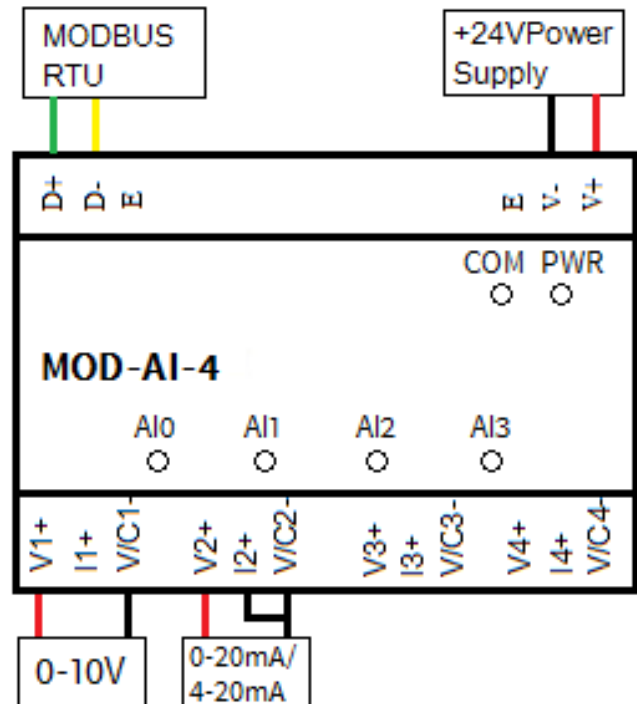

## Modbus Configuration DIP switch acc

### Steps:

1. Open the upper fascia plate of the module.
2. DIP switch S1 for address and DIP switch S2 for baud rate parity.
3. Adjust the DIP switch according to requirements. Refer below image.

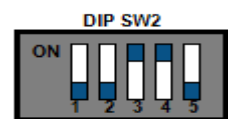
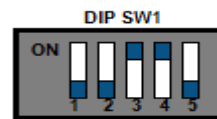

DIP Switch 2		
Baud Rate Configuration		
Baud Rate	Pin 4	Pin 5
9600	OFF	OFF
19200	OFF	ON
57600	ON	OFF
15200	ON	ON
Parity Configuration		
Parity	Pin 3	Pin 2
NONE	OFF	OFF
ODD	OFF	ON
EVEN	ON	OFF
Termination Resistor Configuration (120Ω)		
Termination	Pin 1	
ON	ON	
OFF	OFF	

DIP Switch 1					
Slave ID Configuration					
Slave ID	Pin 1	Pin 2	Pin 3	Pin 4	Pin 5
1	OFF	OFF	OFF	OFF	ON
2	OFF	OFF	OFF	ON	OFF
3	OFF	OFF	OFF	ON	ON
4	OFF	OFF	ON	OFF	OFF
5	OFF	OFF	ON	OFF	ON
6	OFF	OFF	ON	ON	OFF
...	...	...	...	...	...
...	...	...	...	...	...
...	...	...	...	...	...
31	ON	ON	ON	ON	ON

### Messung Systems Pvt. Ltd.

501 Lunkad Sky Vista, Viman Nagar, Pune 411 014, India.

T: +91 20 6649 2800 | e: [info@messung.com](mailto:info@messung.com) | w: [www.messung.com](http://www.messung.com)

## Diagnostic

LED	Color	State	Description
Power	Red	ON	Device is powered
Communication	Yellow	BLINK	Communication in progress (blink frequency depends on baud-rate)
AI CH1 to AI CH4	Green	ON	If Input is present within range
AI CH1 to AI CH4	Green	Blink(1ms Interval)	If Input is out of range

## Modbus Address Mapping

Modbus Register	Modbus Register	Description
AI – CH1	Input Register – 30001	Channel 1 - Analog Input Count Voltage/Current
AI – CH2	Input Register – 30002	Channel 2 - Analog Input Count Voltage/Current
AI – CH3	Input Register – 30003	Channel 3 - Analog Input Count Voltage/Current
AI – CH4	Input Register – 30004	Channel 4 - Analog Input Count Voltage/Current
CH1 – Mode Selection	Holding Register - 40002	0– Disable
CH2 – Mode Selection	Holding Register – 40003	1– Voltage – 0-10V (Default)
CH3 – Mode Selection	Holding Register – 40004	2– Current – 0-20mA
CH4 – Mode Selection	Holding Register - 40005	3– Current – 4-20mA
Filter Setting	Holding Register – 40006	0 – 20SPS (Default) 1 – 60SPS



### SAFETY INSTRUCTIONS

- Installation should only be performed by qualified professionals according to the laws and regulations.
- Do not connect the mains voltage nor any other external voltage to any point of the Modbus connector; it would represent a risk for the entire system. The facility must have enough insulation between the mains (or auxiliary) voltage and the Modbus or the wires of other accessories, in case of being installed.
- Keep the device away from water and do not cover it with clothes, paper or any other material while in use.

